

THIS DRAWING IS UNPUBLISHED.		RELEASED FOR PUBLICATION	
© COPYRIGHT BY TYCO ELECTRONICS CORPORATION. ALL RIGHTS RESERVED.			
AMP PART NO	MATERIAL	PKG TYPE	QTY
8-321871-5	M/F 8-321871-0	BOX	10

LOC	DIST	REVISIONS					
G	14	P	LTR	DESCRIPTION	DATE	DWN	APVD
		F1		REV PER ECR 08-007246	20MAR08	JR	RL

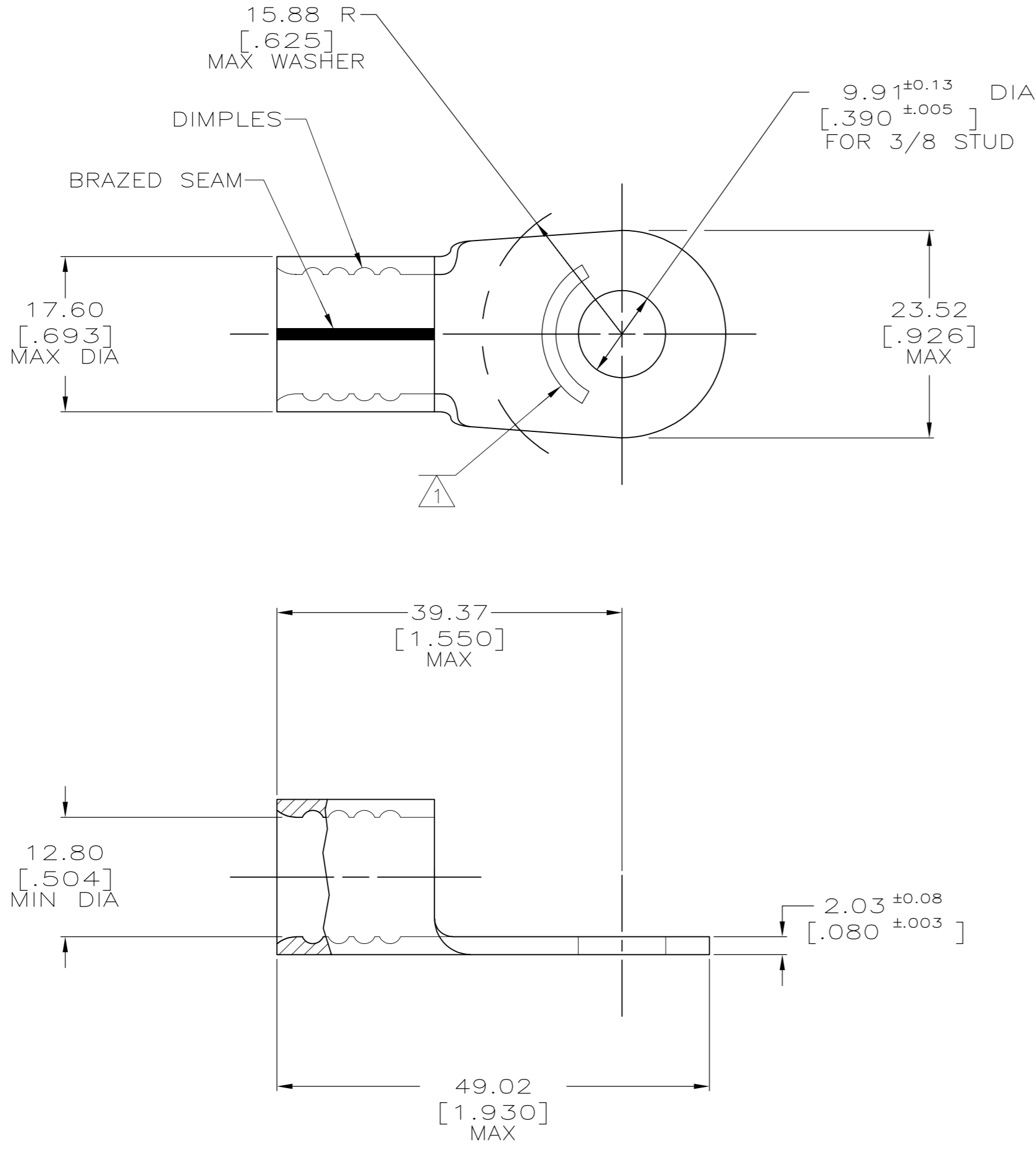

<b>AMP</b> WIRE RANGE	E13288 Listed
2/0 AWG SOLID OR STRANDED	2/0 AWG STRANDED
LR7189 Certified	MILITARY P/N AND CLASS
2/0 AWG SOLID OR STRANDED	MS 20659-120 CLASS 2

- ① STAMP AMP 2/0W\* APPROX AS SHOWN
- ② TIN PL 0.00254[.000100] MIN THK PER MIL-T-10727
- ③ BRIGHT TIN LEAD PL 0.00254[.000100] MIN THK PER MIL-T-10727
- ④ NICKEL PLATE 0.00762 [.000300] MIN EXT. THK PER 112-25-2

<b>AMP INCORPORATED CUSTOMER SERVICE SYSTEMS</b>		MAX RECOMMENDED OPERATING TEMPERATURE: 170° C MAX
FOR ADDITIONAL PRODUCT INFORMATION OR COPIES OF DRAWINGS AND TECHNICAL DOCUMENTS	PRODUCT INFORMATION CENTER 1-800-522-6752	VOLTAGE RATING: NOT APPLICABLE
FOR APPLICATION TOOLING INFORMATION	TOOLING ASSISTANCE CENTER 1-800-722-1111	WIRE CROSS SECTIONAL AREA RANGE: 60.6-76.3mm <sup>2</sup> [119,500-150,500] CIR MILS SOLID OR STRANDED
FOR ORDER ENTRY	1-800-526-5142	THIS DRAWING IS A CONTROLLED DOCUMENT FOR AMP INCORPORATED. IT IS SUBJECT TO CHANGE AND THE CONTROLLING ENGINEERING ORGANIZATION SHOULD BE CONTACTED FOR THE LATEST REVISION.

THIS DRAWING IS A CONTROLLED DOCUMENT.		DWN DK SCHRUM 1/14/94	Tyco Electronics Corporation Harrisburg, PA 17105-3608	
DIMENSIONS: MM [ INCHES ]		CHK AJ KAUFMAN 1/19/94	NAME TERMINAL, RING TONGUE, SOLISTRAND	
TOLERANCES UNLESS OTHERWISE SPECIFIED:		APVD JL MECKLEY 1/19/94	SIZE A2	
0 PLC ± -		PRODUCT SPEC	CAGE CODE 00779	DRAWING NO 321871
1 PLC ± -		APPLICATION SPEC	RESTRICTED TO	
2 PLC ± 0.20[.008]			SCALE 2:1	
3 PLC ± -		WEIGHT	SHEET 1 of 1	
4 PLC ± -			REV F1	
ANGLES ± -				
MATERIAL COPPER PER ASTM B-152 ANNEALED	FINISH SEE TABLE	CUSTOMER DRAWING		